

The image shows a construction site for a deck. A concrete slab is being prepared with a grid of dark metal joists. Each joist is supported by a black plastic pedestal. To the right, a section of the deck is already finished with light-colored wooden planks. In the background, there is a house with white siding and a concrete walkway. A green banner in the top left corner contains the 'millboard' logo and the slogan 'Live. Life. Outside.'

millboard®

Live. Life. Outside.

PLAS-PRO
Ultra-Low Maintenance
Sub Frame Solutions



What is Plas-pro?

Plas-Pro is made from 100% recycled plastic. Using selected graded materials and cleverly engineered processes, Plas-Pro not only brings the key environmental benefits, but the assurance of superior quality performance.

Being impervious to water ingress Plas-Pro will not rot, swell or split like wood, making it particularly suitable around water and damp environments such as jettys, fishing platforms, roof terraces and boardwalks - ensuring a maintenance-free solution.



Why Plas-Pro?

Plas-Pro offers many longer term advantages above traditional construction materials such as timber and composite systems. Designed for the discerning specifier and client looking for durable and cost effective lasting solutions.

Plas-Pro complements our terrace pedestal products and the unique Millboard external flooring range, enabling us to offer a complete, full turn key, non-rot external flooring system



Life Cycle Durability

Designed to outlast traditional timber and wood based materials, Plas-Pro gives the ultimate life cycle costs efficiencies.

It is widely specified by designers, architects, and installers for use in commercial, local authority and residential applications. Plas-pro offers a wholly maintenance free system making it the perfect choice when longevity, function and low maintenance matter.

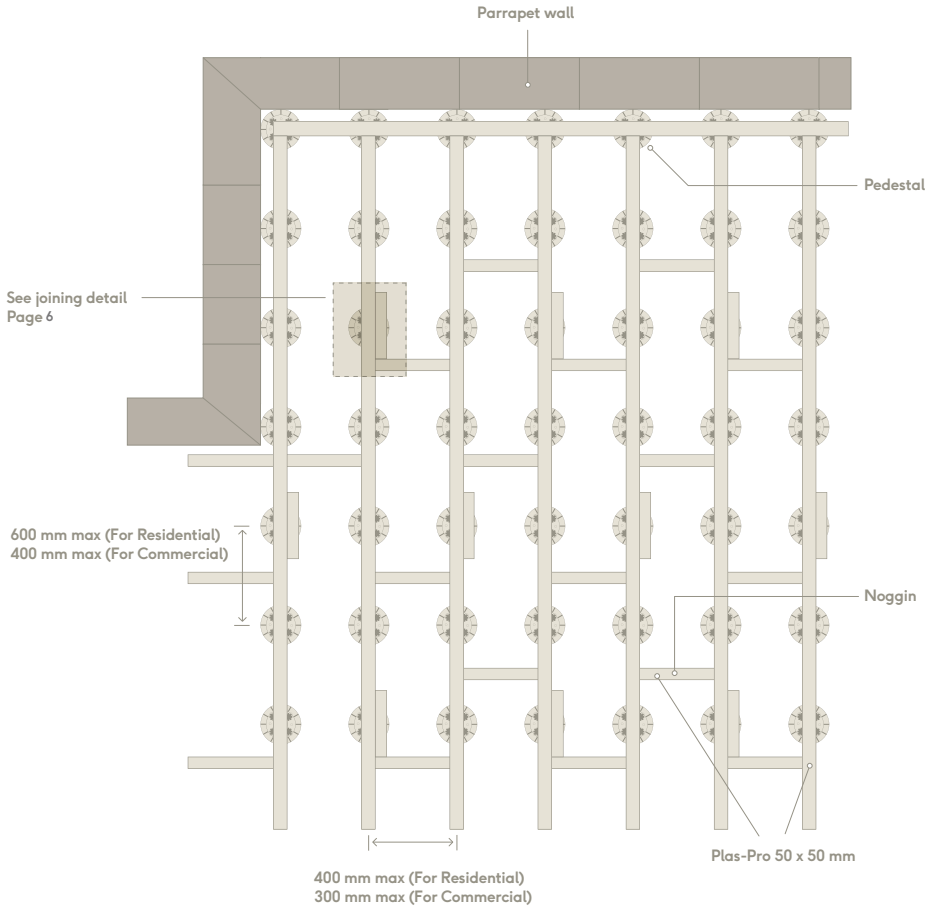

Roof terrace standard subframe laying pattern

application
details



Joining roof subframe battens

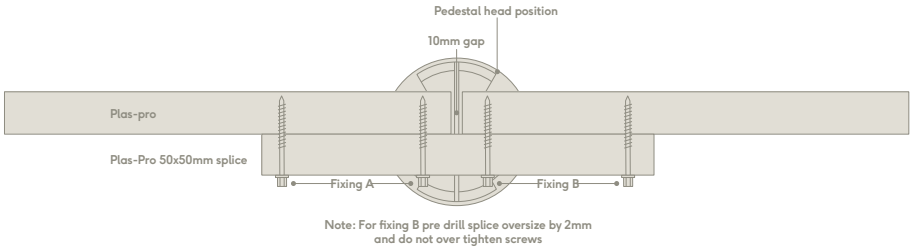
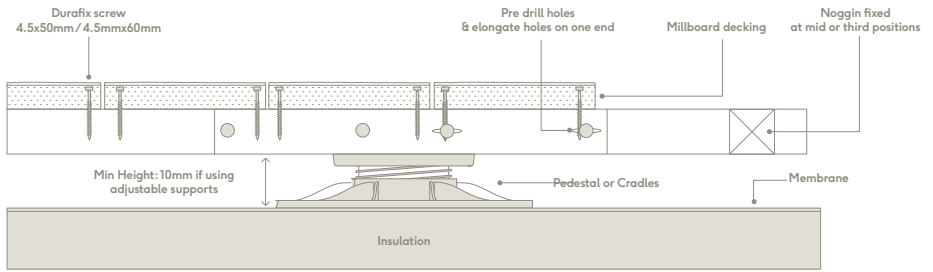

application
details

Mixed support systems

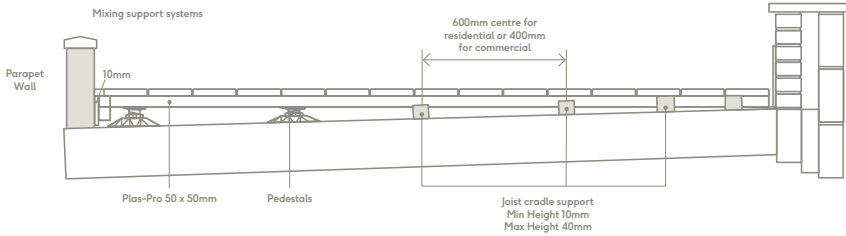

Height restricted situations

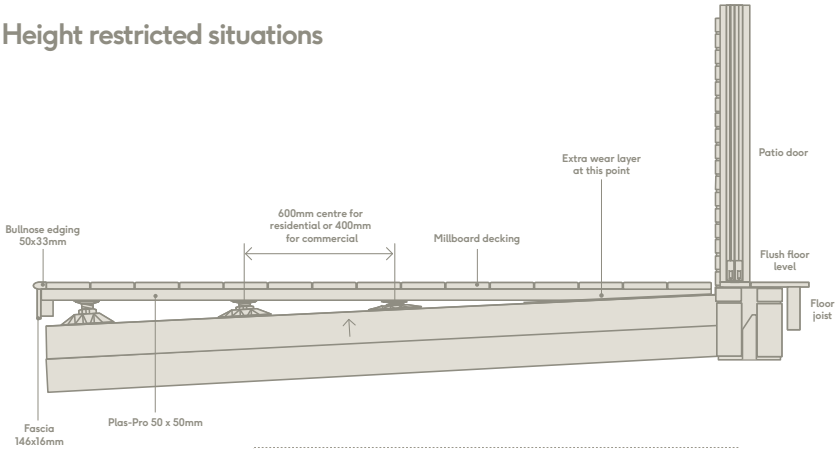

WARNING

Make sure screws that protrude through the Plas-Pro are cut off before laying the battens on to the roof membrane. We recommend a protective layer under the battens.

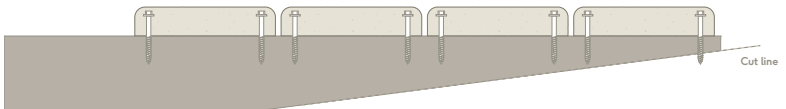

millboard®

Live.Life.Outside.

Typical pedestal section

Side View

Sizes:

- 40 - 56 mm
- 50 - 70 mm
- 70 - 110 mm
- 110 - 160 mm
- 150 - 210 mm
- 100 mm extension collars

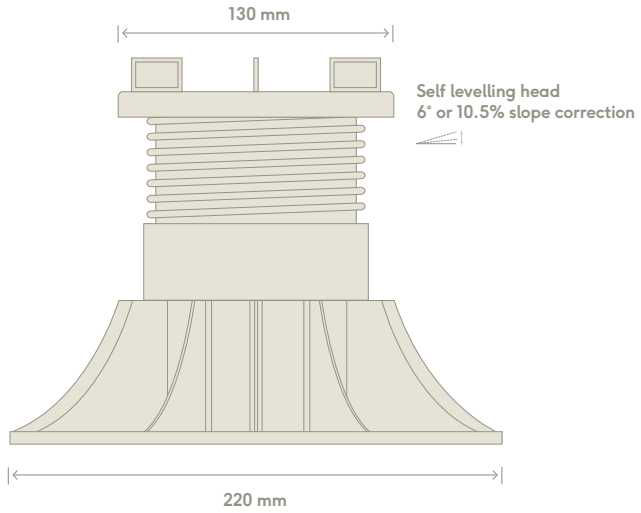

Top View

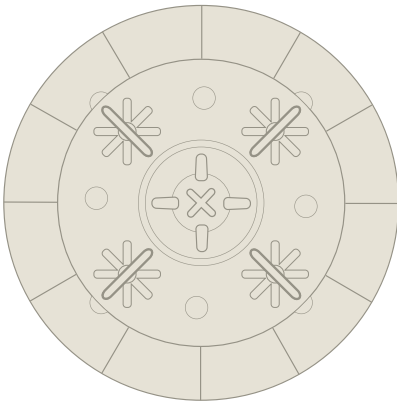

Bottom View - Dotted line shows cut marks

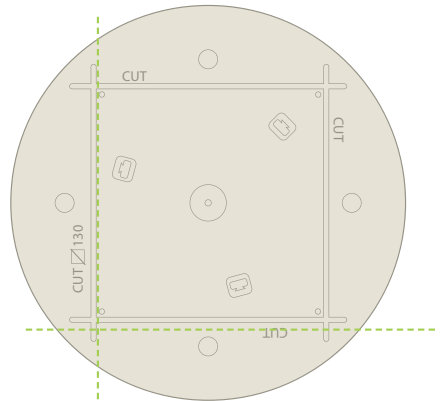

application
details

10-40mm joist cradle

Side View

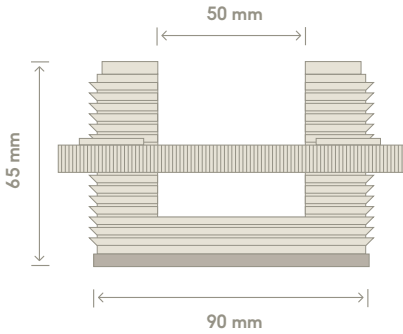

Top view with Plas-Pro

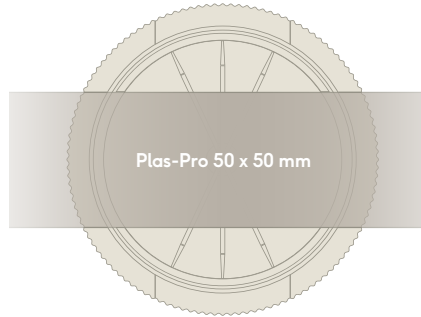

Top View

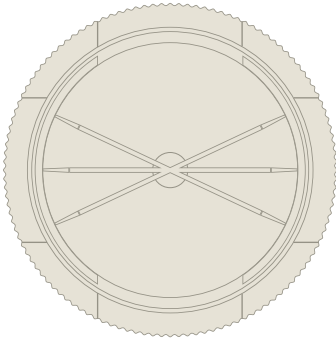

Bottom View

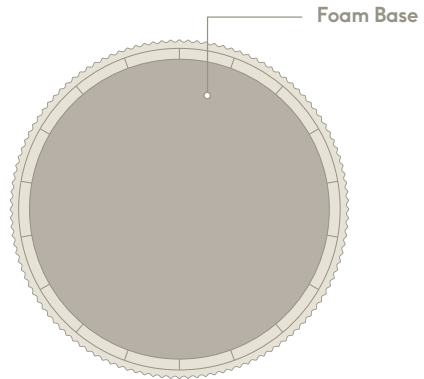

millboard®

Live.Life.Outside.

Joist cradle data

Material	Recycled Nylon (glass filled)
Height Range	10-40mm
Compressive Strength	6Kn/m ²
Base Diameter	90mm
Bearer Capacity	45-50mm
Bearer/Cradle Connection	Loose Laid
Biological Chemical	Resistant to moulds, algae, alkali, bitumen
Working Temperature	-20°C - 120°C
Cradle Spacing	600mm centres along joist (residential) or 400mm centres along joist (commercial). Joists at 400mm centres (residential) or 300mm centres (commercial)

Fully tested to conform to the loading conditions for flooring as described in bs 5399

Pedestal technical data

Material	PP Polypropylene (recyclable), UV resistant
Biological/Chemical	Resistant to moulds, algae, alkali, bitumen
Height Range	40mm - 1000mm
Compression	2100 Kg (certified compression data available on request)
Base Diameter	210mm / 220mm
Head Diameter	130mm
Spacer Tab Thickness	4mm
Working Temperature	-40°C - 120°C

application details

Boardwalk

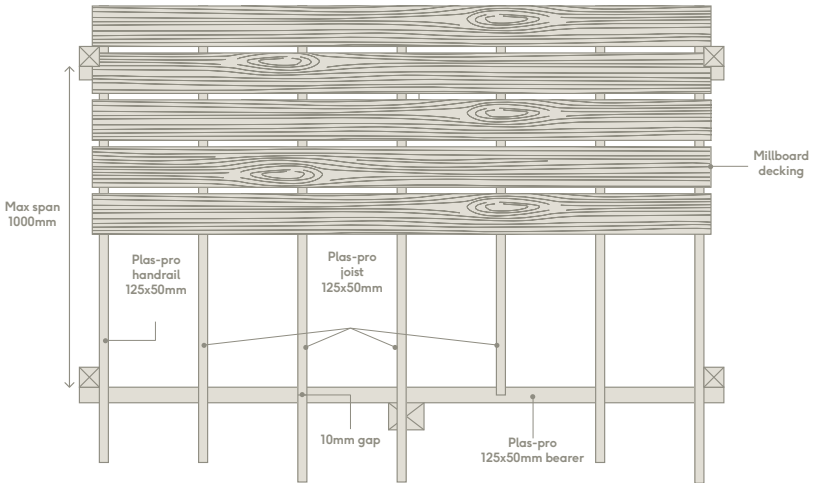
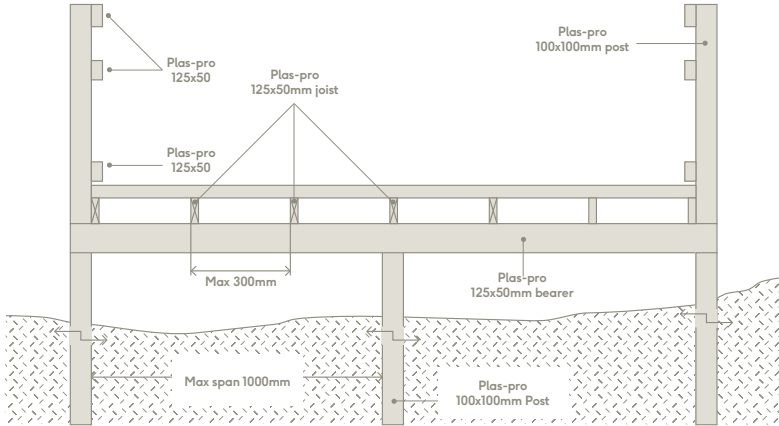

Joining detail

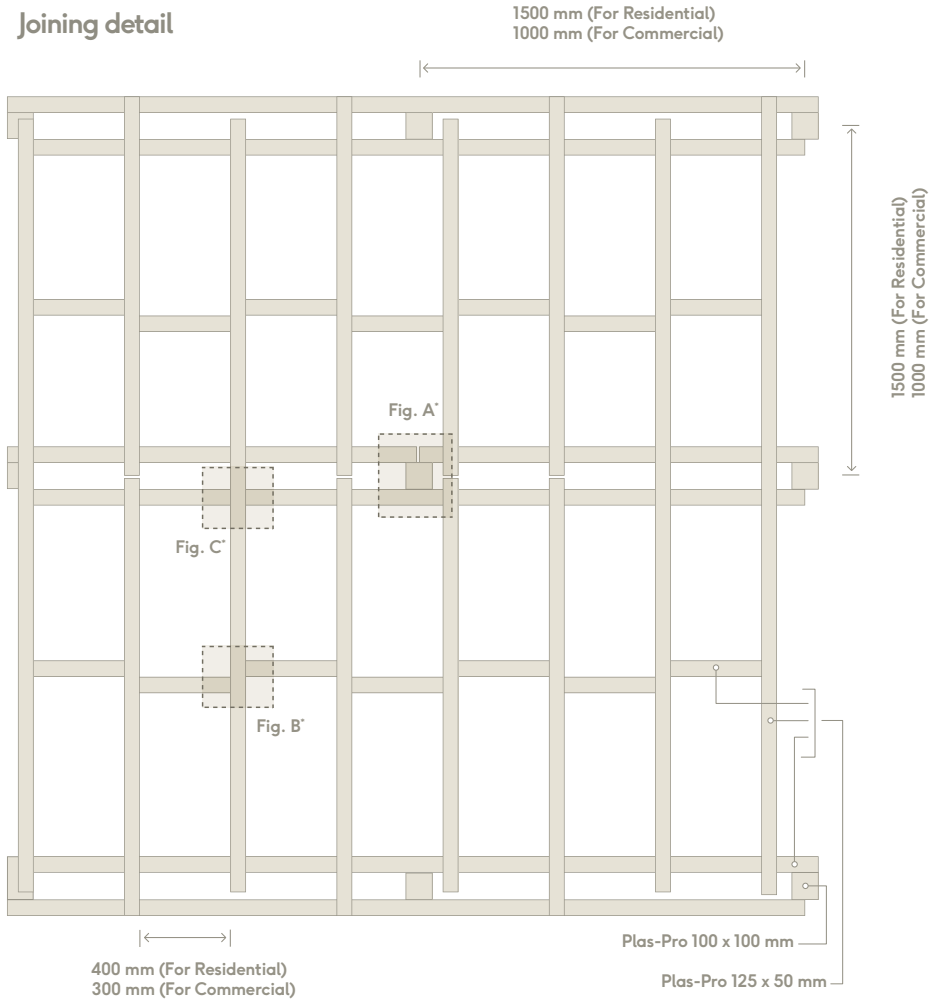

application
details

Plas-Pro subframe construction:

100 x 100mm posts to be 1/3 in the ground 2/3 out of the ground with a minimum of 400mm in the ground

125 x 50mm bearers to be fixed to posts with 2 no. Durafix Hexhead screws with oversized pilot holes

125 x 50mm joists to be fixed to bearers at every intersection

125 x 50mm joists to have staggered joists across bearers with a 10mm gap between joist ends

Residential projects based on up to 1.5kN/m²

Commercial projects based on up to 4kN/m²

*Fig A, B and C detailed guides on pages 22 and 23

100 x 100 x 3000mm - Plas-pro post - P1010B300

125 x 50 x 3000mm - Plas-pro joist - P1205B300

50 x 50 x 2400mm - Plas-pro batten - P0505B240

60 x 30 x 2800mm - Plas-pro batten - P0603H280

millboard®

Live.Life.Outside.

Fig A. Fixing joists to the post:

Plas-Pro Subframe Screws, Hex drive 90x6.3mm
 Plas-Pro must always be pre drilled and also pilot holed

Step 1: Drill 15mm dia. hole at an angle 10mm deep (optional if head of fixing needs to be below the surface)

Step 2: Pilot hole 5mm dia. Drill 60mm deep

Step 3: Relief hole 8mm dia. Drill all the way through the joist

Step 4: Drive screw in

Visit website for up to date cad drawing www.millboard.co.uk/downloads

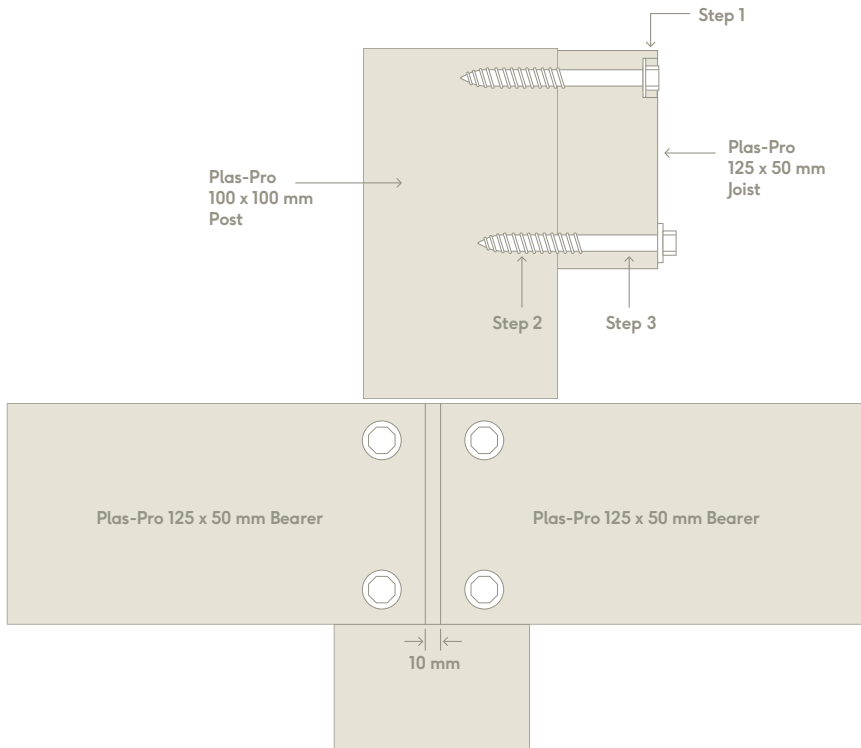
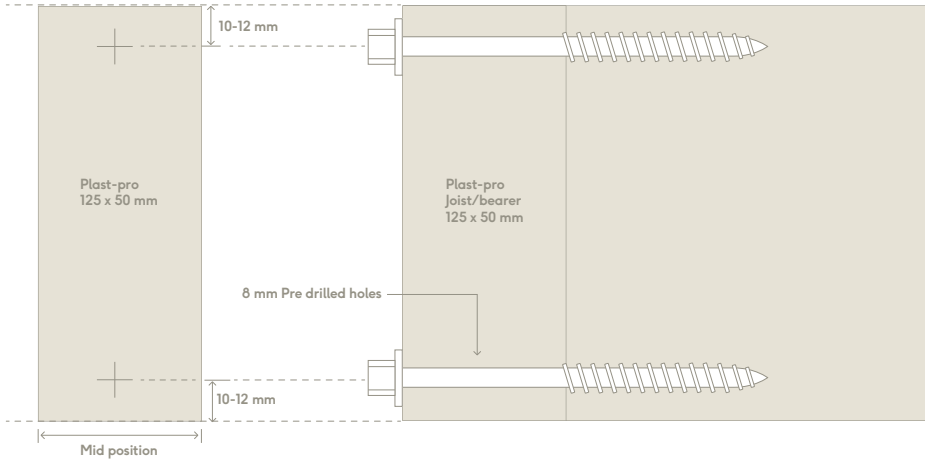
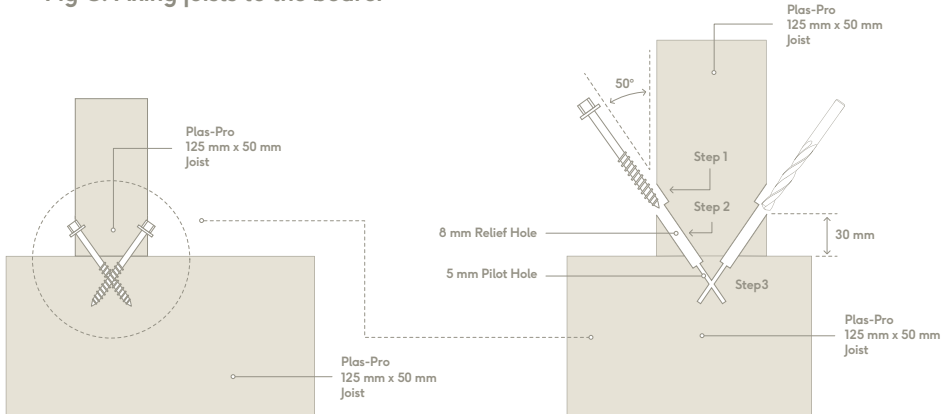

Fig B. Cross section view



NOTE: Screw fixing method using Durafix hex head screws is for braces or noggins. If a joist is to be fixed then the use of truss clips with screws is recommended

Fig C. Fixing joists to the bearer



Plastic subframe material test data

Technical data in an overview		125 X 50mm			
Testing:	Standard din en iso	Result			
3 Point bend	178	Flexural stress	-5° C	Mpa	35.1
		Bending e-modulus			2,261
		Flexural stress	23° C		24.0
		Bending e-modulus			1,424
		Flexural stress	65° C		16.5
		Bending e-modulus			856
Tensile	527-2	Strength		Mpa	15.6
		Tensile e-modulus			1,490
		Elongation		%	1.7
Timed tensile	899-1	Tensile e-modulus	1 Hour	Mpa	1,043
		Tensile e-modulus	24 Hours		975
		Tensile e-modulus	100 Hours		852
Timed 3 point bend	899-2	Bending e-modulus	1 Hour	Mpa	1,159
		Bending e-modulus	24 Hours		943
		Bending e-modulus	100 Hours		816
Pressure characteristics	604	Compression strength	1% Stretch	Mpa	2.5
			2% Stretch		5.3
			10% Stretch		27.9
			Compressive stretch at yield		29.0
		Pressure e-modulus			
Charpy test	179	Impact resistance		Kj/m ²	12
Impact shore hardness	868	Shore hardness			62
Density test	1183-1	Density		G/cm ³	1.0529
Water absorbtion	62	23° C, 50%r.L		%	<1
		23° C in water			<1
		100° C in water			<1
Resistance	60093 ⁴	Surface resistance		Ω	1.5 X 10 ¹⁴
		Specific surface resistance			1.5 X 10 ¹⁵
		Flow/contact resistance			>2.0 X 10 ¹⁴
		Specificflow/contact resistance			>8.4 X 10 ¹⁴
Ball striking test	2039-1	Ball striking hardness		N/mm ²	39.52
Thermal expansion		Coefficient of thermal expansion		1/°C	0.0001510648
Screw pull out force		Drilled material		N	8,230
		Non pre-drilled		N	8,140

Plastic subframe material test data

Technical data in an overview		50 X 50 and 100 x 100mm			
Testing:	Standard din en iso	Result			
3 Point bend	178	Flexural stress	-5° C	Mpa	21.2
		Bending e-modulus			1,289
		Flexural stress	23° C		11.6
		Bending e-modulus			581
		Flexural stress	65° C		4.6
		Bending e-modulus			162
Tensile	527-2	Strength		Mpa	9.65
		Tensile e-modulus			659
		Elongation		%	13.8
Timed tensile	899-1	Tensile e-modulus	1 Hour	Mpa	316
		Tensile e-modulus	24 Hours		
		Tensile e-modulus	100 Hours		202
Timed 3 point bend	899-2	Bending e-modulus	1 Hour	Mpa	380
		Bending e-modulus	24 Hours		271
		Bending e-modulus	100 Hours		235
Pressure characteristics	604	Compression strength	1% Stretch	Mpa	1.8
			2% Stretch		3.3
			10% Stretch		13.3
			20%Stretch		18.2
		Pressure e-modulus			
Charpy test	179	Impact resistance		Kj/m ²	412
Impact shore hardness	868	Shore hardness			53
Density test	1183-1	Density		G/cm ³	1.0062
Water absorbtion	62	23° C, 50%r.L		%	<1
		23° C in water			<1
		100° C in water			<1
Resistance	60093 ⁴	Surface resistance		Ω	3.2 X 10 ¹³
		Specific surface resistance			3.2 X 10 ¹⁴
		Flow/contact resistance			9.0 X 10 ¹³
		Specificflow/contact resistance			4.5 X 10 ¹⁴
Ball striking test	2039-1	Ball striking hardness		N/mm ²	18.44
Thermal expansion		Coefficient of thermal expansion		1/°C	0.00018993
Screw pull out force		Drilled material		N	7,500
		Non pre-drilled		N	7,500

A photograph showing the installation of light-colored wooden decking on a roof terrace. The decking is laid over a metal frame of black beams supported by black plastic spacers. A small tree is planted in a planter box on the terrace. The background shows a modern building with large glass windows.

millboard®

Live. Life. Outside.

UK Head Office,
Castle Court, Bodmin Road,
Coventry CV2 5DB

T: +44 (0)24 7643 9943
E: enquiries@millboard.co.uk

www.millboard.co.uk